

### Product Description

- Patented electric flame technology.
- Realistic flame effect, LED inner glow logs and ember bed.
- Refractory brick-look interior (DF2608 only).
- Clean, self-trimming design – no separate trim required.
- 120 volt plug-in firebox with thermostat controlled fan-forced heater.
- Operates with flame only or flame and heat.
- Safe, clean electric operation.
- Adjustable interior light and flame speed control.
- Includes on/off remote control.
- Dimensions 27 3/8" W x 23 1/2" H x 8 13/16" D



Top: 26" plug-in self-trimming firebox (NBD2608).  
Inset: Model with refractory brick-look interior (DF2608).



### Specifications

Model	Description	Volts	Watts	BTU	Total Amps	Weight (lb/kg)
NBD2608	Plug-in firebox, includes built-in thermostat, flame on/off control and separate switches for flame speed, light control and heater, on/off remote control.	120	1500	5200	12.5	55 / 25
DF2608	As above, but includes refractory brick-look interior	120	1500	5200	12.5	55 / 25

### Dimensions

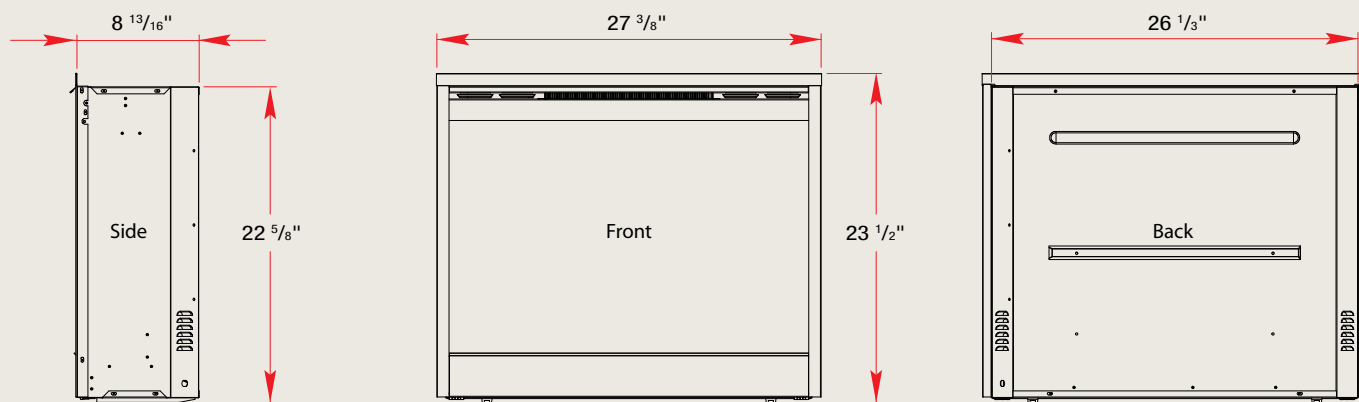

Protected by one or more of the following patents: U.S. Patents: 6,050,011, 6,269,567, 6,190,019, 6,564,485, 5,642,580, 6,615,519, 6,363,636, 6,047,489, 6,718,665, 6,350,498, 6,162,047, 6,385,881, 7,134,229, D514,677, 7,162,820, 7,194,830. Canadian Patents: 2,175,442, 2,310,367, 2,310,073, 2,204,106, 2,310,362, 2,310,414, 2,262,338, 2,321,716, 2,299,927, 105175. Other patents pending. Specifications, finishes and dimensions are subject to change and should be taken as a guide only.